

## BENEFITS

### Highest Efficiency

Panel efficiency of 18.1% is the highest commercially available for residential applications

### Attractive Design

Unique design combines high efficiency and an elegant, all-black appearance

### More Power

Delivers up to 50% more power per unit area than conventional solar panels

### Reliable and Robust Design

Proven materials, tempered front glass, and a sturdy anodized frame allow panel to operate reliably in multiple mounting configurations



## 225 SOLAR PANEL

EXCEPTIONAL EFFICIENCY AND APPEARANCE

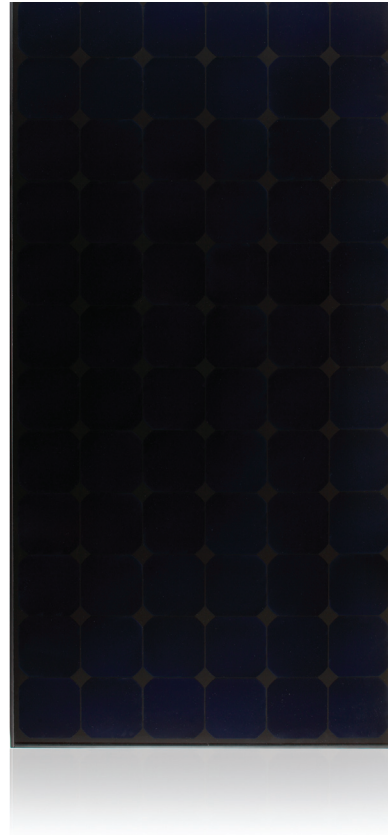

**The SunPower 225 Solar Panel provides a revolutionary combination of high efficiency and attractive, uniform appearance.** Utilizing 72 next generation SunPower all back-contact solar cells and an all-black backsheet, the SunPower 225 elegantly delivers an unprecedented total panel conversion efficiency of 18.1%. The panel's reduced voltage-temperature coefficient and exceptional low-light performance attributes provide far higher energy delivery per peak power than conventional panels.

### SunPower's High Efficiency Advantage - up to 50% More Power

Comparable systems covering 25 m <sup>2</sup> / 270 ft <sup>2</sup>		
	Conventional	SunPower
Watts / Panel	165	225
Efficiency	12.0%	18.1%
kWs	3.0	4.5

#### Electrical Data

Measured at Standard Test Conditions (STC): irradiance of 1000/m<sup>2</sup>, air mass 1.5g, and cell temperature 25° C

Peak Power (+/-5%)	Pmax	225 W
Rated Voltage	Vmp	41.0 V
Rated Current	Imp	5.49 A
Open Circuit Voltage	Voc	48.5 V
Short Circuit Current	Isc	5.87 A
Maximum System Voltage	IEC, UL	1000 V, 600 V
Temperature Coefficients		
	Power	-0.38% /°C
	Voltage (Voc)	-132.5 mV/°C
	Current (Isc)	3.5 mA/°C
Series Fuse Rating		20 A
Peak Power per Unit Area		181 W/m <sup>2</sup> , 16.8 W/ft <sup>2</sup>
CEC PTC Rating		207.1 W

#### Mechanical Data

Solar Cells	72 SunPower all-back contact monocrystalline
Front Glass	3.2 mm (1/8 in) tempered
Junction Box	IP-65 rated with 3 bypass diodes
Output Cables	900mm length cable / Multi-Contact connectors
Frame	Anodized aluminum alloy type 6063
Weight	15 kg, 33 lbs

#### IV Curve

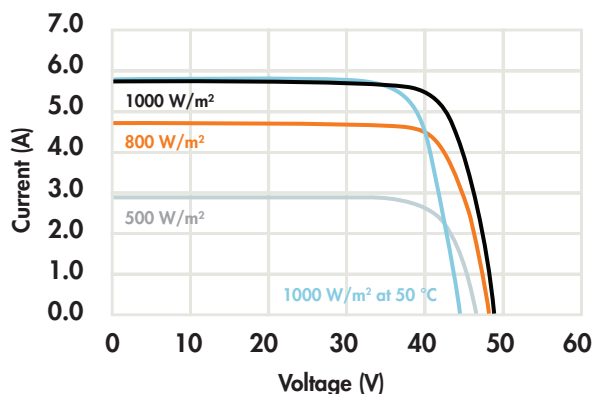

Current/voltage characteristics with dependence on irradiance and module temperature.

#### Tested Operating Conditions

Temperature	-40° C to +85° C (-40°F to +185°F)
Max load	50 psf (2400 Pascals) front and back
Impact Resistance	Hail - 25mm (1 in) at 23 m/s (52 mph)

#### Warranty and Certifications

Warranty	25 year limited power warranty 10 year limited product warranty
Certifications	IEC 61215, Safety tested IEC 61730 Tested to UL 1703 by UL or CSA, Class C Fire Rating

#### Dimensions

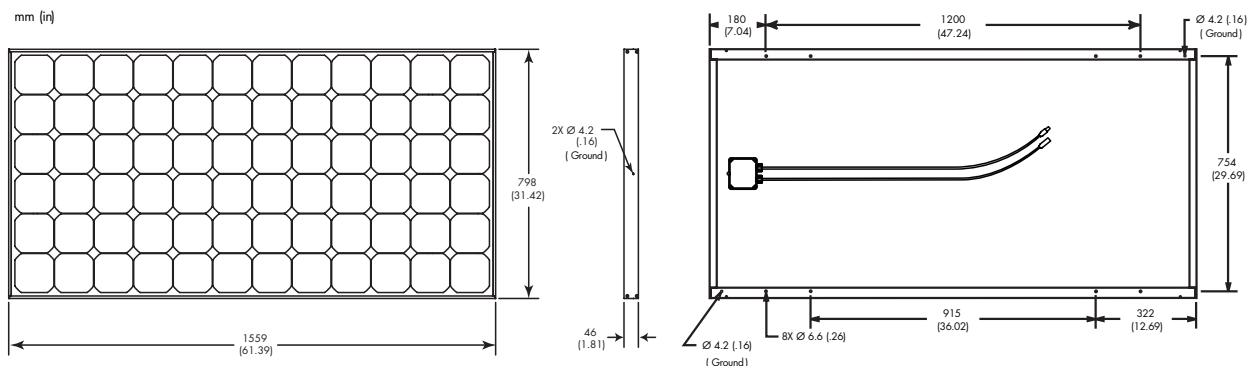

**CAUTION: READ SAFETY AND INSTALLATION INSTRUCTIONS BEFORE USING THE PRODUCT.** Go to [www.sunpowercorp.com/panels](http://www.sunpowercorp.com/panels) for details

#### About SunPower

SunPower designs, manufactures and delivers high-performance solar electric technology worldwide. Our high-efficiency solar cells generate up to 50 percent more power than conventional solar cells. Our high-performance solar panels, roof tiles and trackers deliver significantly more energy than competing systems.