

SUNEARTH inc.



SolaRay^{AC}

**SRCC OG-300 Certified Solar Water Heating System
Type: AC Circulating Pump and Differential Control
Installation, Operation and Maintenance Manual**

SOLARAY^{AC}

DOMESTIC SOLAR WATER HEATER SYSTEM

INSTALLATION, OPERATION AND MAINTENANCE MANUAL

The SolaRay™ domestic solar water heating system has gone through an extensive design, technical and performance review by the Solar Rating & Certification Corporation (SRCC). The installation of your SolaRay system is intended to be executed by properly licensed and experienced professional contractors in accordance with SRCC Standard OG-300, "Operating Guidelines and Minimum Standards For Certifying", and must conform to applicable federal, state and local regulations, codes, ordinances and standards governing the installation of solar water heating systems.

The solar energy system described by this manual, when properly installed and maintained, meets the minimum standards established by the SRCC. This certification does not imply endorsement or warranty of this product by the SRCC.

OG-300 system certification is granted to SunEarth by the SRCC. It may not be used for any commercial purpose without the prior written consent of SunEarth. SunEarth must approve any deviation from the materials and methods described in this manual in writing.

SunEarth SolaRay solar water heating systems can be protected against freeze damage to temperatures as low as -60°F (-51°C). This system should not be installed in any area that has experienced ambient air temperatures below -60°F. Use Table 4, Section 4 of this manual to determine the required concentration of propylene glycol and distilled water to provide adequate freeze protection in your specific climate.

Dow Chemical "Dowfrost HD" propylene glycol heat transfer fluid shall be used in this system as the primary freeze protection agent. Unauthorized fluid substitutions can result in a threat to health, welfare and safety and may cause the system piping to freeze.

All component warranties, express or implied, are voided if uninhibited glycol, potable or distilled water are substituted for the specified heat transfer fluid described in this manual, or if the heat transfer fluid is not maintained in accordance with the manufacturer's instructions.

Freeze tolerance limits are based upon an assumed set of environmental conditions. Extended periods of cold weather, including ambient air temperatures above the specified limit may cause freezing in exposed parts of the system. It is the owner's responsibility to protect the system in accordance with SunEarth's instructions if the ambient air temperature approaches the specified freeze tolerance limit.

TABLE OF CONTENTS

Preface

- 1) Introduction.....1
- 2) System Description and Operational Principle.....1
- 3) Installation Requirements - General3
- 4) Installation Requirements - Specific4
- 5) Start Up Procedures 14
- 6) Three Modes of System Operation 14
- 7) Isolating the Major Components and Shut Down Procedures 15
- 8) Summer Vacation Recommendations 15
- 9) Maintenance and Troubleshooting 16
- 10) Solaray System Component Parts 17
- 11) Estimated Component Life..... 19
- 12) System Model Numbers 19
- 13) Collector Specifications20
- 14) SunEarth Collector Warranty Statement22

PREFACE

Let us first offer two words of grateful appreciation. Thank You! We sincerely appreciate your business. SunEarth also wishes to say thank you for "going solar". Solar water heating systems help to reduce our nation's dependence on polluting fossil fuels, minimize the greenhouse gas emissions associated with conventional water heating and, very importantly, lower your monthly utility costs.

Established in 1978, SunEarth is a leading U.S. solar equipment manufacturer. Our products include industry standard Imperial™ and Empire™ solar water heating collectors, CopperHeart™ integral collector storage systems, SunSiphon™ packaged thermosiphon systems, SunBurst™ all copper absorber plates, and Solar Strut™ mounting hardware. We also build specialty collectors for unique architectural and building applications. SunEarth SRCC OG-300 certified solar water heating systems are sold by leading solar, plumbing and building contractors throughout the United States.

Your SolaRay solar water heating system has been designed to meet exacting SRCC OG-300 certification requirements. The components found in your system have been selected by your installation contractor for their proven reliability, longevity and performance in your specific region of the country.

1) INTRODUCTION

Solar water heating systems are climate and site specific appliances. Different types of solar systems are installed around the world in accordance with regional weather and water quality conditions. System performance varies as a function of the household hot water load, including daily showers, laundry and kitchen uses, average ground water and ambient air temperatures, the home's roof pitch and orientation, and, of course, the seasonal intensity of solar radiation. These variables, some of which change from home to home on the same neighborhood street, will determine how much energy and money your SolaRay system will save on an annual basis.

Your SolaRay solar system is known as a "forced circulation" system because it utilizes a mechan-

ical pump to efficiently circulate the Dow Chemical Dowfrost HD propylene glycol heat transfer fluid (HTF) throughout the system. The HTF protects the collector piping from freezing and inhibits scaling deposits that can reduce performance in "open-loop" systems utilizing potable water as the HTF. Proper application and maintenance of the HTF can protect your Solaray solar water heating system to minus 60° Fahrenheit.

This manual is intended as a basic solar water heating primer. Our goal is to familiarize you with the proper installation, operation, and maintenance of your SolaRay solar system. This system is required to be installed by properly licensed solar or plumbing contractors in accordance with SRCC Standard OG-300 and all applicable national, state and local codes, ordinances and regulations governing solar water heating installations, as well as good trade practices. Failure to follow the procedures and practices described in this manual can void the manufacturer's warranty for specific component parts.

This manual covers installations utilizing one or two SunEarth solar collectors with a single solar storage tank and also two tank systems that include a solar storage tank and a conventional water heater. For simplicity, the singular form will be used throughout this manual when referring to all of these components and system permutations. Frequent reference is made throughout this manual to specific component parts. The placement of each component can be seen in system schematic figures 16 and 17. A description of each component and its function is found in Section 10.

2) SYSTEM DESCRIPTION AND OPERATIONAL PRINCIPLE

The key components in the SolaRay solar water heating system include the SunEarth solar collector, solar storage tank with integral heat exchanger, circulation pump, differential thermostat, expansion tank, pressure gauge, mixing valve and the non-toxic propylene glycol heat transfer fluid (HTF).

The SunEarth solar collector is the heart of the SolaRay system. Simply stated, when the sun is shining, heat energy is absorbed by the solar collector's all copper absorber plate and trans-

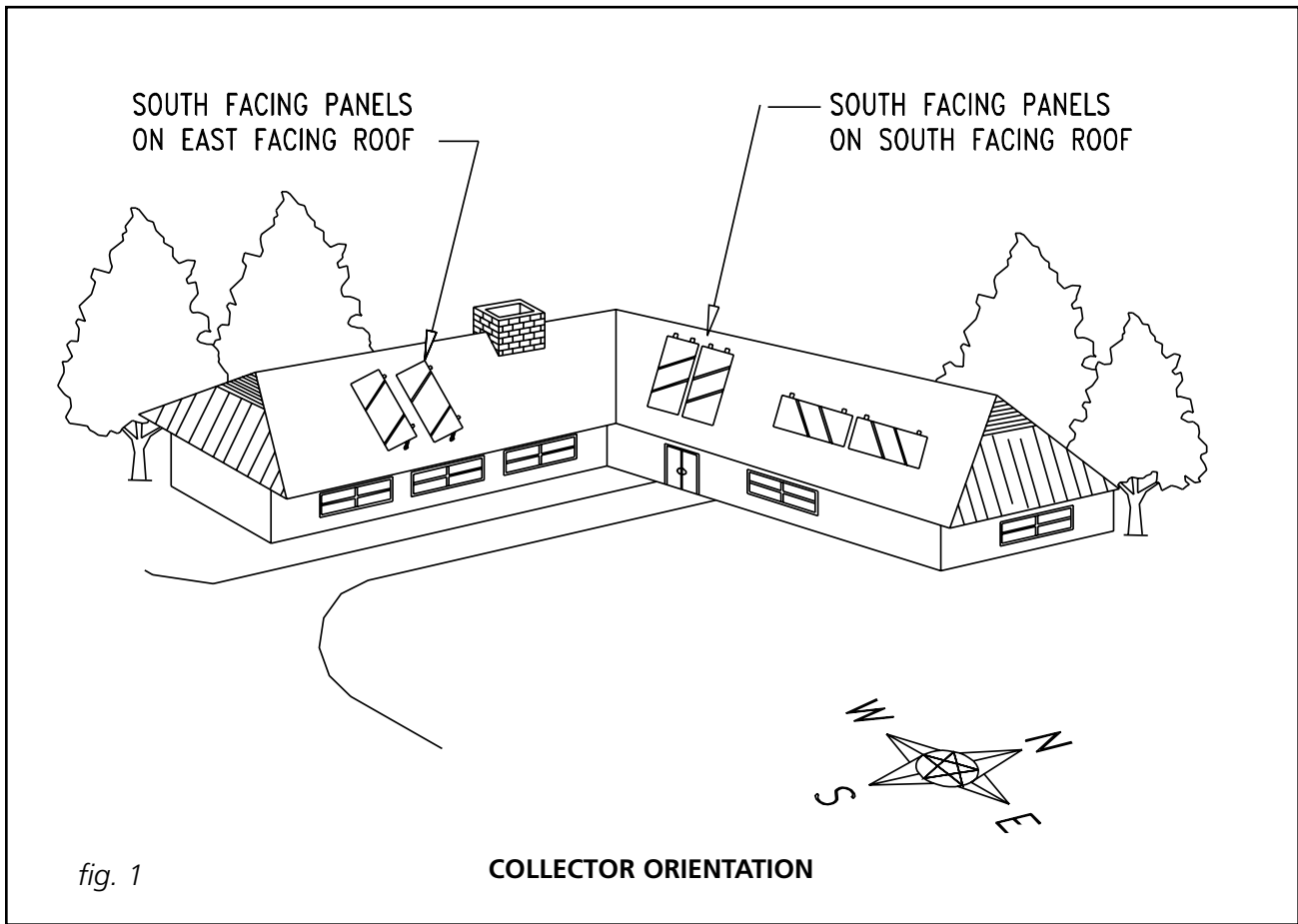

ferred to the HTF circulating through the solar collector. The system pump efficiently circulates this heated fluid through the collector piping and integral tank heat exchanger. The heat exchanger consists of a 120' length of copper tubing wrapped around the solar storage tank. As the HTF passes through the heat exchanger the heat in the fluid is transferred by conduction to the potable water in your solar storage tank. As this process is continuously repeated during the average sunny day the temperature in your solar storage tank rises.

The circulating pump in a solar water heating system may be favorably compared with the human heart. To continue the analogy, the differential thermostat, or controller, is the brain in the system. The controller uses 10K ohm thermistors, or sensors, to constantly monitor the temperature difference between the hottest and coldest points in the system and to automatically turn the circulating pump on and off throughout the day.

When the solar collector absorber plate is

approximately twelve degrees hotter than the temperature in the bottom of your solar storage tank, the controller will turn the circulating pump on. When the temperature difference has been reduced to four degrees, the controller automatically turns the pump off.

Both single and double tank Solaray systems are designed to provide three separate modes of system operation. The system will, (1) accommodate 100% solar operation, (2) serve as a pre-heater to your solar storage tank or back-up water heater, or (3) bypass the solar collector and run 100% on utility power. Section Six provides

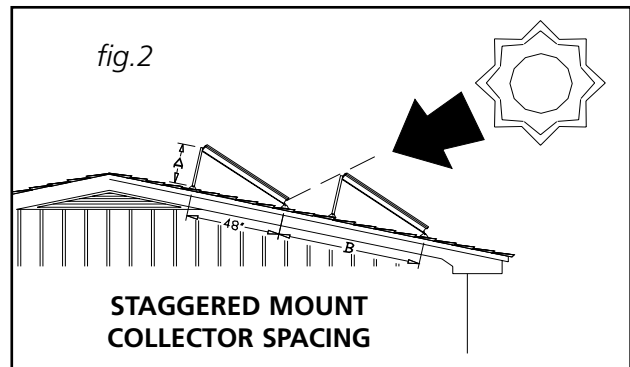

TABLE 1

LATITUDE			25°N		30°N		35°N		40°N		45°N		50°N	
COLL. TILT			35°		40°		45°		50°		55°		60°	
			A	B	A	B	A	B	A	B	A	B	A	B
FLAT			29	96	33	113	37	145	41	145	44	145	48	145
5°	1/12		25	83	29	93	33	113	37	132	41	133	44	141
9°	2/12		22	74	26	82	30	77	34	110	38	115	41	118
14°	3/12		17	66	22	72	26	82	30	92	34	95	38	98
18°	4/12		14	61	18	66	22	74	26	82	30	85	34	87
ROOF	23°	5/12	10	58	14	60	18	66	22	72	26	74	30	77
PITCH	27°	6/12	7	58	11	58	15	61	19	66	23	68	27	70
	30°	7/12	4	58	8	58	13	58	17	62	21	65	25	66
	34°	8/12	0	58	5	58	9	58	13	58	17	60	22	62
	37°	9/12	0	58	3	58	7	58	11	58	15	58	19	58
	40°	10/12	0	58	0	58	4	58	8	58	13	58	17	58
	43°	11/12	0	58	0	58	2	58	6	58	10	58	14	58
	45°	12/12	0	58	0	58	0	58	4	58	8	58	13	58

DIMENSIONS A AND B ARE DESIGNATED IN INCHES

instructions for setting the system for automatic operation in each of these three modes.

The Dowfrost HD HTF protects your SolaRay solar system against freezing. Dowfrost HD can provide reliable freeze protection at temperatures as low as minus 60° Fahrenheit if properly applied and maintained. **Use of uninhibited propylene glycol, plain water or a concentration of these two fluids as the HTF in this system is strictly prohibited.**

Propylene glycol can degrade over time. The process of degradation is accelerated in presence of oxygen and/or heat. We strongly encourage you to establish a preventative maintenance schedule with your installation contractor. The HTF pH level must be maintained between 8 and 10 in order to prevent glycol oxidation and corrosion of the collector piping. **SunEarth's collector warranty specifically excludes freeze damage for any reason and absorber plate damage resulting from the oxidation of the propylene glycol HTF.**

In order to completely protect the integrity of the solar collector and piping, the system is designed to be drained manually if subject to extended periods of disuse or persistent hard freeze conditions below minus 60° Fahrenheit. (See Sections 8.1 and 8.2 below).

3) INSTALLATION REQUIREMENTS - GENERAL

3.1 The contractor shall obtain all required permits and approvals.

3.2 The installation shall conform to all federal, state and local regulations, codes, ordinances and standards governing solar water heating system installations, and the contractor shall adhere to sound building safety and trade practices. Special consideration must be given to building code requirements for the penetration of structural members and fire rated assemblies.

3.3 The solar collector must be located in a structurally sound area of the roof that will

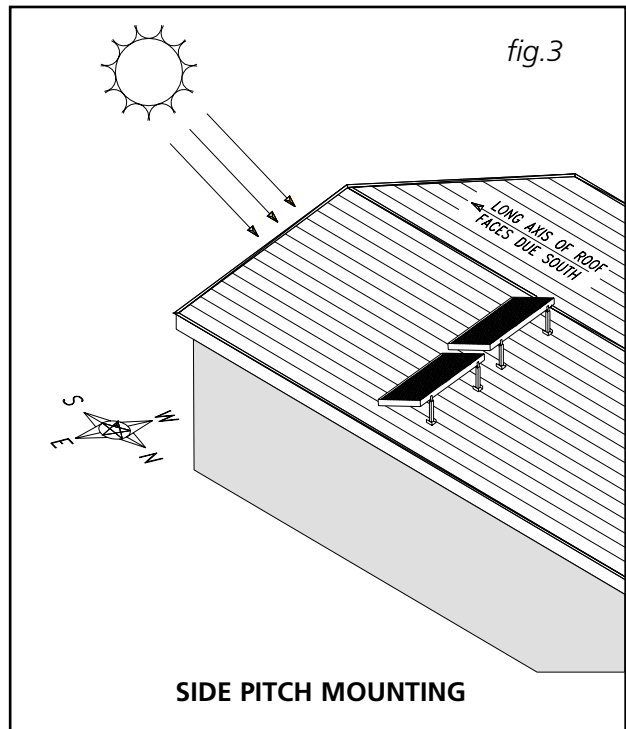

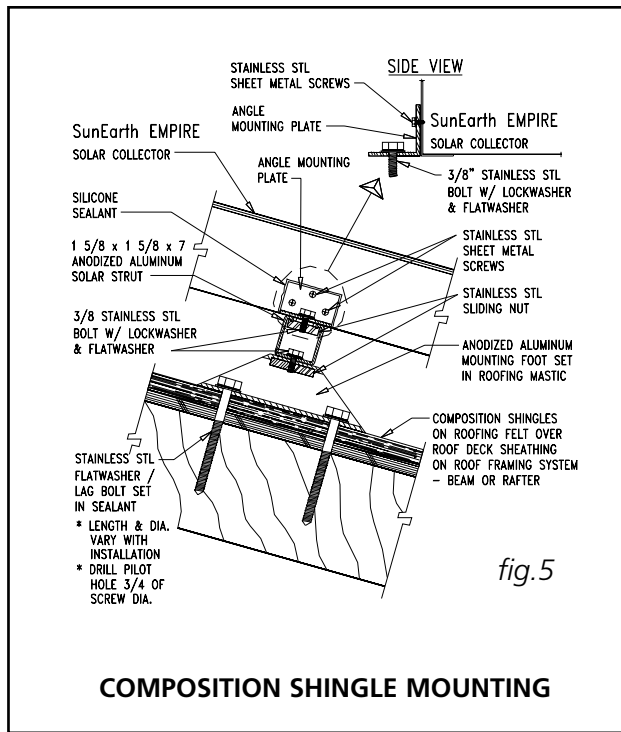
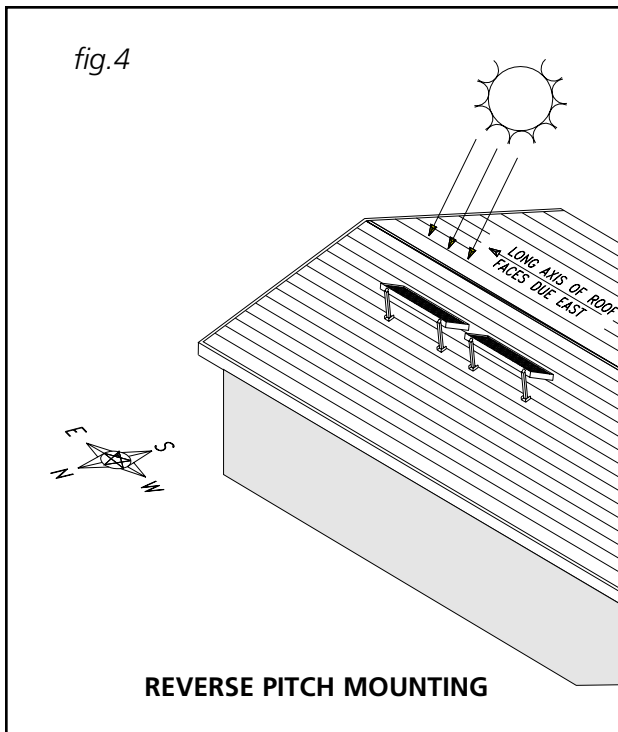

be unshaded for the majority of the day all year round. Adjacent buildings and trees should be checked for possible winter shading. An instrument such as the Solar Pathfinder can be used for solar site analysis. (Solar Pathfinder can be reached at 605-528-6473).

- 3.4 Before the installation the contractor shall inspect the condition of the roof and notify the homeowner of any existing roof damage or necessary repairs.
- 3.5 The homeowner and contractor shall confirm the location of all roof and ground mounted components in advance of the installation.

4) INSTALLATION REQUIREMENTS - SPECIFIC

4.1 Collector Orientation

The performance of solar water heating systems in the Northern Hemisphere is optimized when the collector is mounted facing True South. Performance, however, suffers very little when the collector is oriented no more than 45° East or West of True South. The collector should be unshaded by any permanent obstacle between 9:00 a.m. and 3:00 p.m. on any day of the year.

4.2 Collector Tilt

Optimal annual efficiency is achieved by tilting the solar collector at an angle that equals your latitude plus an additional 10°. This tilt angle favors the lower winter sun when collector performance is at it's lowest and minimizes over-heating during the hottest summer months.

The solar collectors in a two collector staggered mount installation must be spaced far enough apart to prevent winter shading. Figure 2 and

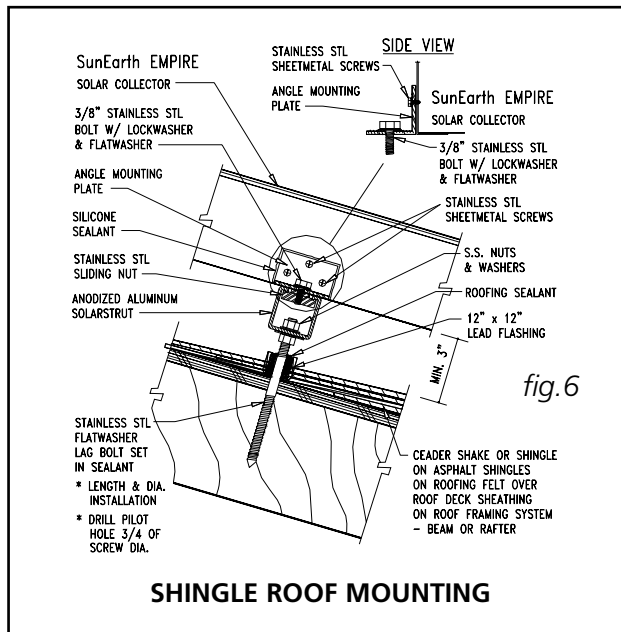

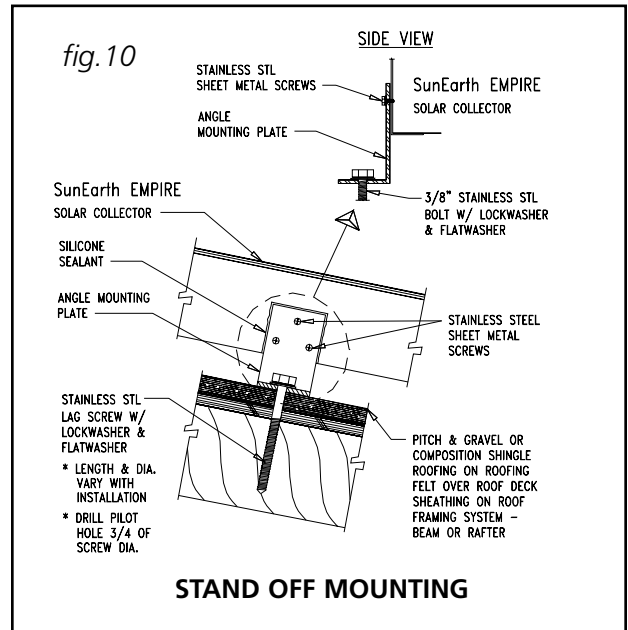
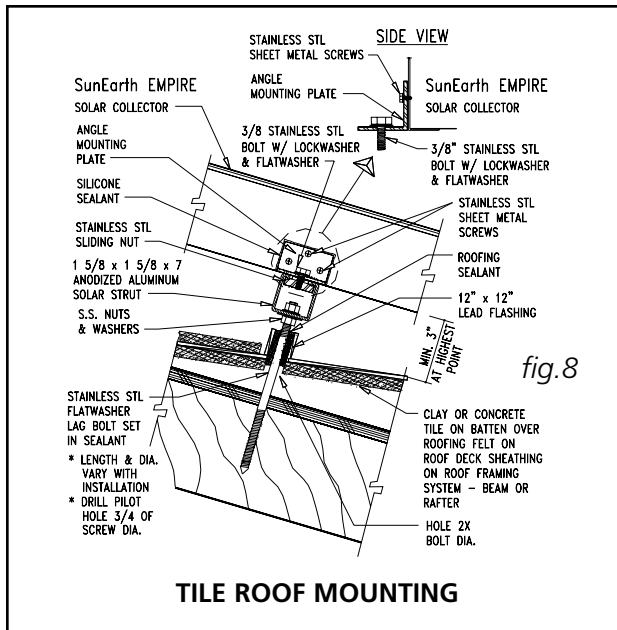
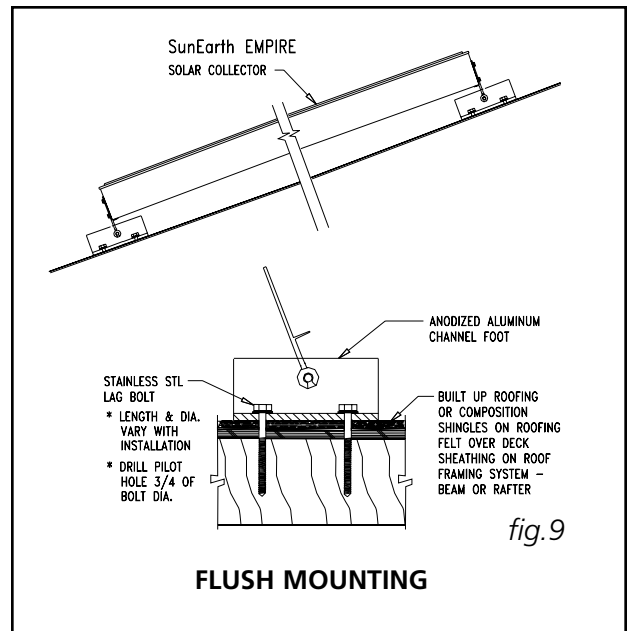
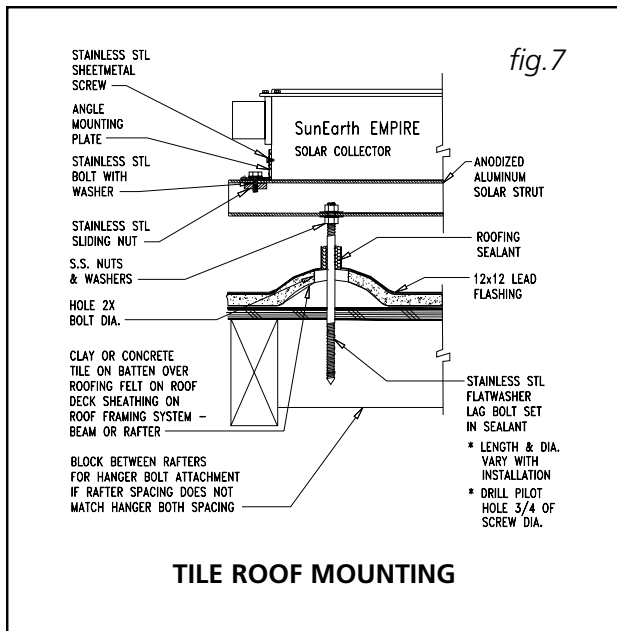

Table 1 show the correct spacing between collectors to prevent shading on December 21, when the sun is at its lowest angle.

4.3 Basic Mounting Procedures

The SunEarth solar collector in your SolaRay solar system can be mounted in either a vertical or horizontal orientation on the roof (See Figure 1). Although the collector is protected from freeze conditions by the glycol HTF and does not normally need to be drained, it is still important to slope the collectors just slightly to allow for complete drainage if necessary. The recommended slope is 1/4" per foot of horizontal run.

To ensure proper water drainage from the glazing the collectors must maintain a minimum angle from horizontal of at least 10°. Never mount the collector directly or parallel to a flat roof surface. Use SunEarth "Solar Strut" tilt mount kits to rack the collectors to the proper angle.

The collector should be mounted as close to the storage tank as possible to minimize heat loss in the piping runs. If the home has attic access, mounting the collectors near the roof peak provides for additional attic workspace.

The solar collector should be mounted on the

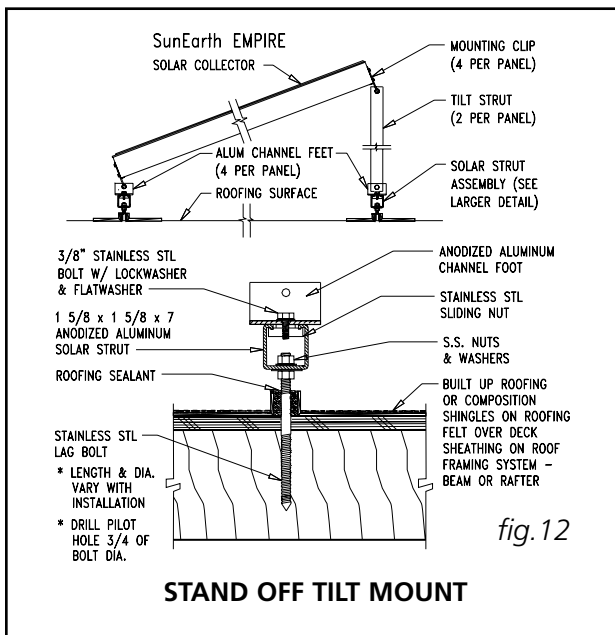
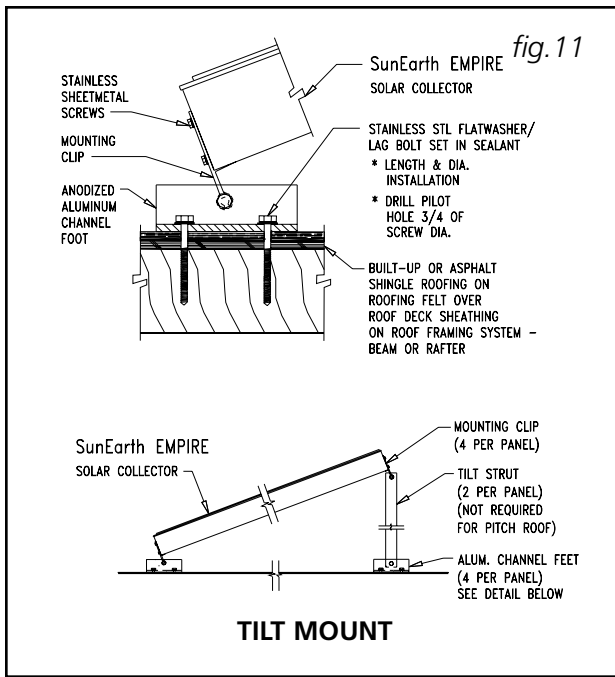

roof in accordance with these general principles:

4.3.1 The most important structural consideration is to securely anchor the solar collector and the Solar Strut mounting hardware to the structural members of the roof with stainless steel hanger or lag bolts. The solar collector must be attached to the mounting hardware as detailed in Figures 5–12. (Note: The drawings in this manual detail mounting hardware for the SunEarth Empire series collector. Drawings for the Imperial series collector are available upon request).

4.3.2 The collector must be raised from the roof surface to allow for rainwater and debris to pass under the collectors and for proper ventilation of the roofing material. There should be at least 1 1/2" of clearance between the roof surface and the bottom of the solar collectors.

4.3.3 In selecting mounting hardware and fasteners it is extremely important to avoid galvanic corrosion resulting from the direct contact of incompatible metals. Use of SunEarth anodized aluminum "Solar Strut" mounting hardware and stainless steel lag or hanger bolts, lock washers and round washers is recommended. In climates subject to severe winters or high humidity use of galvanized fasteners is prohibited.

4.3.4 Preserving the integrity of the roof membrane is the most important roofing consideration. Ensure that all roof penetrations required to plumb and mount the solar collector are properly flashed and sealed in accordance with standard roofing practices. Tremco "POLYroof" is the recommended elastomer for sealing roof penetrations. Henry Co. 204, 208 or 209 roof mastic or Dow Corning Glazing Sealant also are acceptable sealants.

4.3.5 If the region is subject to hurricane conditions, additional steps may be required to secure the collector and mounting hardware to the structural members. In certain areas of the country, local building codes may require collector wind load testing or prescribe specific mounting procedures. Consult your local building department.

4.4 Collector Loop Pipe Insulation

The collector loop cold supply and hot return lines must be well insulated with a high quality flexible closed cell insulation to minimize heat loss. The wall thickness of the pipe insulation should not be less than 3/4". A 1" wall thickness is required in all areas prone to annual hard freeze conditions. When it comes to pipe insulation the rule is simple: thicker is better. The specified insulation material is Rubatex Insul-Tube 180 or equal.

To the extent possible, slide the insulation material over the pipe without cutting or taping. All butt joints must be sealed with contact adhesive. The use of rigid polyethylene pipe insulation is prohibited. The temperatures generated by your

collector in the summer months or under stagnation conditions can melt this type of material.

Any above ground exterior pipe insulation is subject to UV degradation and must be wrapped with foil tape or painted with two coats of high quality water-based acrylic resin coating as supplied by the insulation manufacturer. Rubatex UV Protective Coating or equal is the required coating material.

4.5 Collector Plumbing

SunEarth requires the use of all copper and brass fittings in the collector loop plumbing. Couplings rather than unions should be used to join the collectors to avoid leaks and fluid loss. Use only lead-free solder. Engelhard Silvacrite 100 or equal is required. Use of 50/50 lead solder is expressly prohibited. Use of galvanized steel, CPVC, PVC, or any other type of plastic pipe is prohibited.

Piping in new solar installations can be covered with dirt, grease, solder flux or other impurities that over time affect the quality of the glycol HTF. A thorough cleaning is required before charging the system with glycol. Carefully review the cleaning procedures in "Charging The System" outlined below.

All vertical piping between the storage tank and the collector shall be supported at each story or at maximum intervals of ten feet (10'). Copper plumbers tape or tube strap is required. The pipe insulation may not be compressed or crimped by the strapping material.

The installation of all horizontal and vertical piping may not reduce the performance or rating of

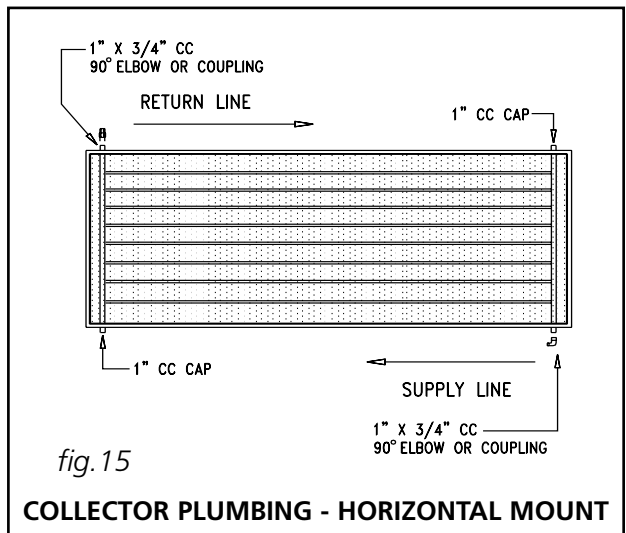
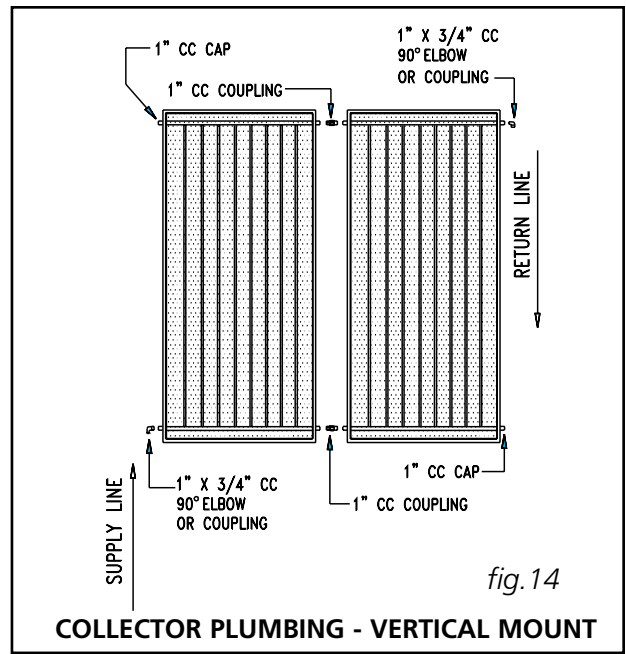
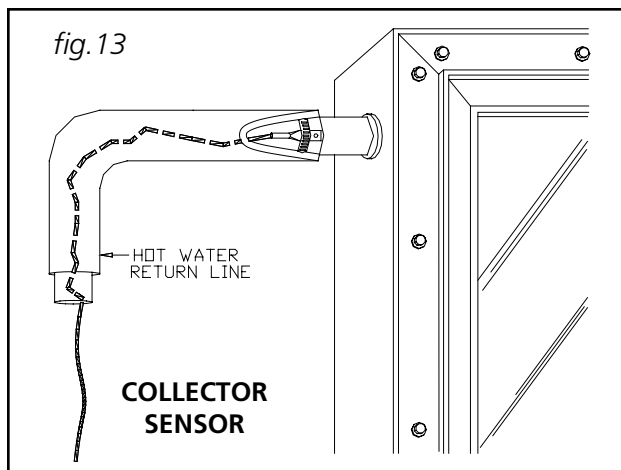

any structural member or fire rated assembly. Adhere to all applicable local codes and ordinances.

4.6 Collector Sensor Placement

The collector sensor must be located on the hot water return line as close to the collector as possible. Sensors are typically accurate to $\pm 1/2^\circ\text{F}$ if properly installed and weatherized. To maximize sensor accuracy, attach the flanged portion of the sensor to the SunEarth collector header pipe with a stainless steel hose clamp. Wire nuts used to connect the sensor and low voltage wiring shall be all plastic, sealed with silicone and thoroughly wrapped in electrician's tape.

NOTE: WHEN TWO COLLECTORS ARE REQUIRED, PLUMB IN PARALLEL.

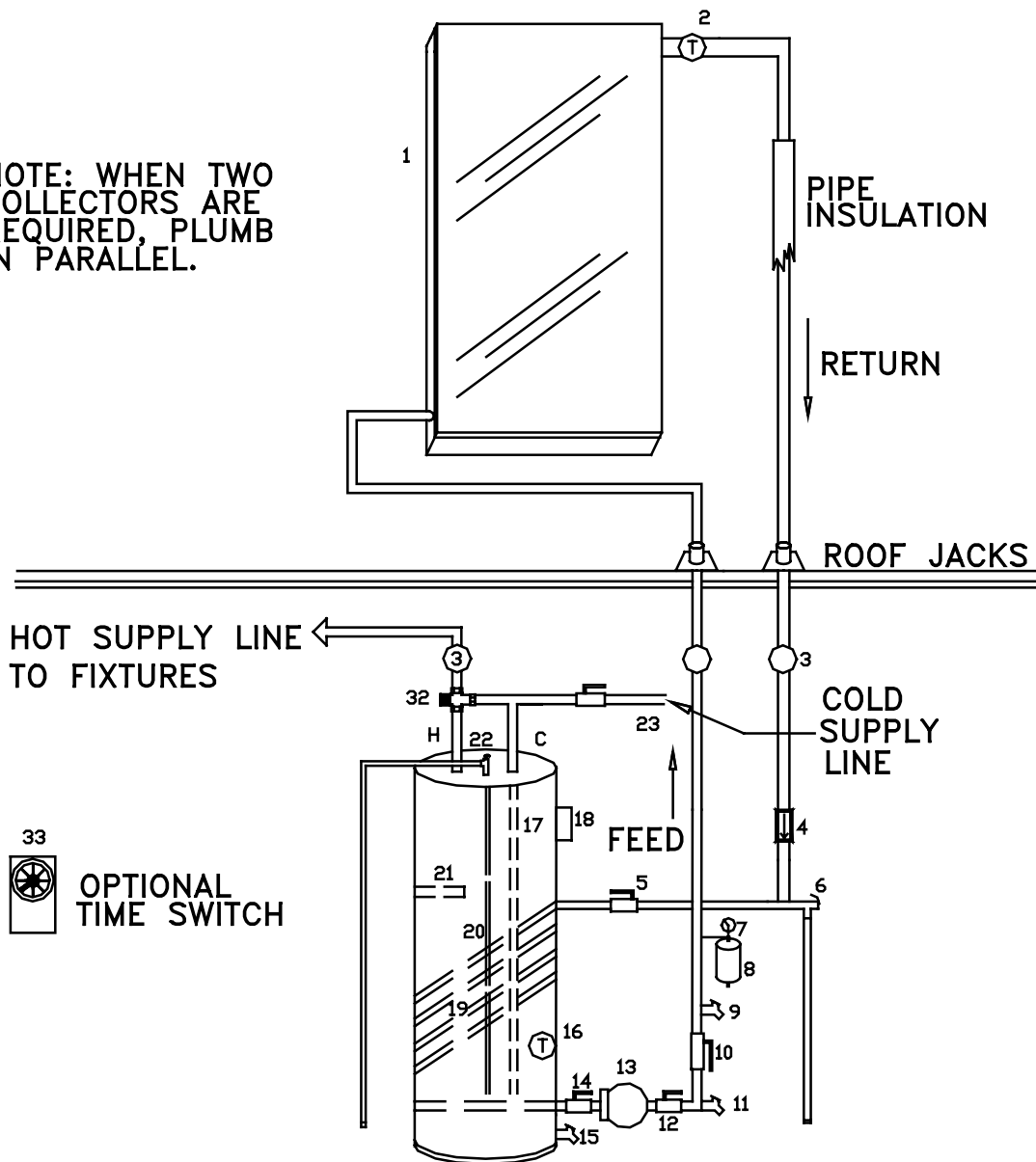

fig.16

SINGLE TANK SYSTEM SCHEMATIC

The sensor "bundle" must be placed under the rubber pipe insulation covering the collector header. Thoroughly wrap and weatherize the insulation with electrician's tape or insulation tape as provided by the manufacturer (Rubatex Insul-Tape or equal). See Figure 13 for collector sensor installation detail.

4.7 Low Voltage Wiring

The low voltage wiring used to connect the sen-

sors to the controller should be a minimum 18 AWG. The wiring should be bare or tinned copper, two conductor, PVC insulated, with a PVC UV rated gray jacket suitable for exterior use. Use Eastman Wire & Cable No. 5704, Belden Wire and Cable No. 8461 or equal.

4.8 Installing the Solar Storage Tank and Expansion Tank

In plumbing the solar storage tank and expansion

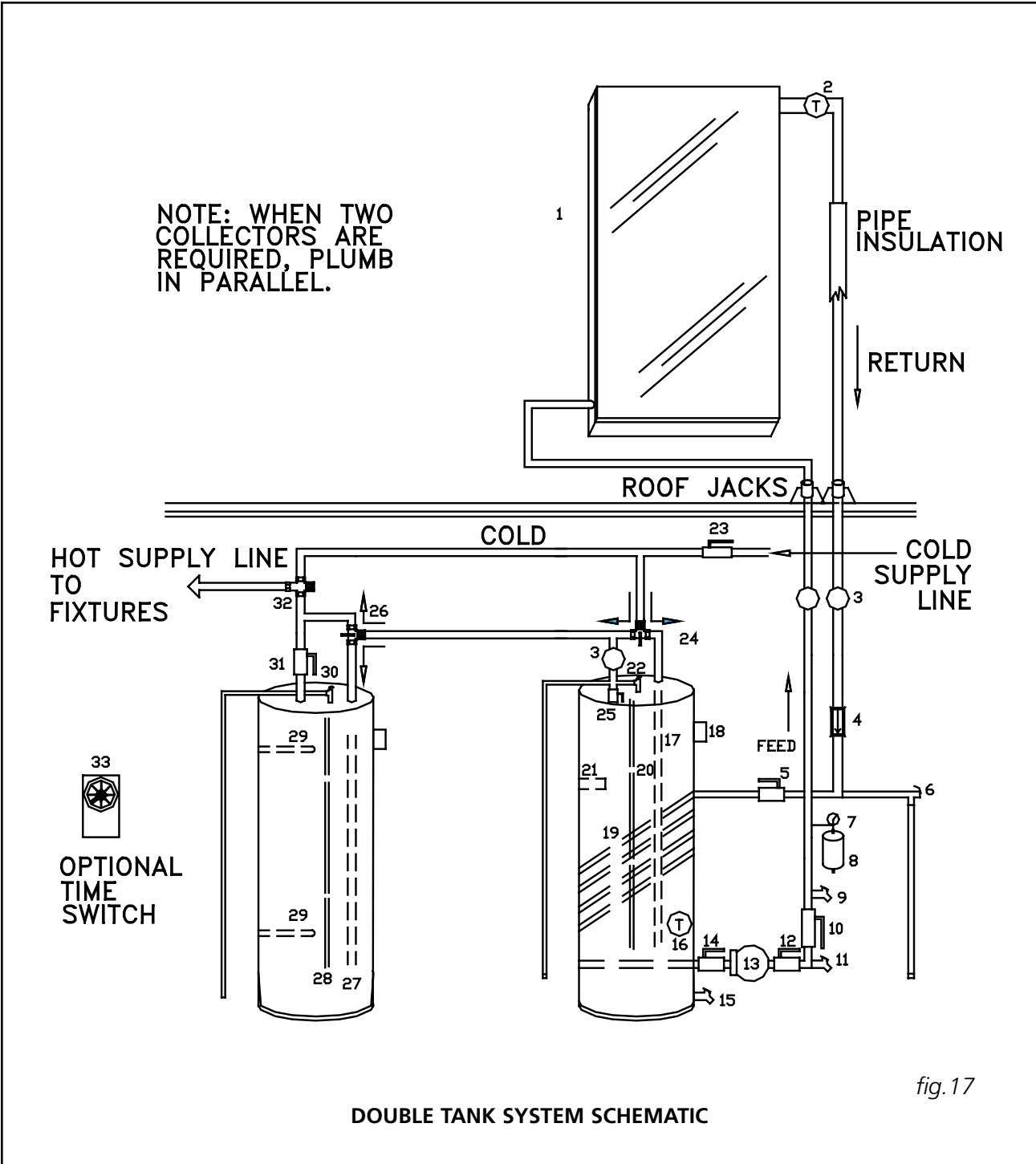

tank make sure that all the components are accessible and easy to reach. Provide for clear access to the storage tank, pump, expansion tank, mixing valve, time clock and other key components. If a component in the potable water side of the system may require future service or maintenance make the connections with brass unions. Use only brass nipples and unions and copper and brass fittings in plumbing the solar

storage tank and expansion tank. The use of galvanized fittings or nipples, di-electric unions, CPVC, PVC or other plastic pipe is prohibited.

Hard copper connections to the city cold water supply line and the home hot water feed lines are recommended. The gaskets in standard water heater flex hose connectors can become brittle and compressed over time and begin leaking on the water heater. If not detected in a timely

manner even a small drip or leak may cause serious damage to the tank's electrical components or, in extreme cases, may cause the tank to leak from the outside in.

Tank plumbing is required to provide for the isolation of the solar storage tank from the city cold water supply line by means of an isolating ball valve (No. 23).

Line thermometers shall be installed in the collector supply and return lines to allow for a simple diagnostic check of proper system operation. On a sunny day the hot water return line should be approximately 5 – 12° warmer than the water in the collector supply line. Compare the temperature readings in the two line thermometers (No. 3).

In a single tank system install a third thermometer (No. 3) directly after the mixing valve above the solar storage tank. In a two tank system you may install the third thermometer either directly above the hot outlet on the solar storage tank or after the mixing valve on the back-up water heater.

The circulation pump shall be the Grundfos model UPS15-42F, 115 volt, or equal. The pump shall be prewired with a 6' line cord so that it can be plugged directly into the 115 volt receptacle on the side of the differential control. Two way ball valves must be installed on either side of the circulating pump (Nos.12 and 14) so that the pump can be isolated from the collector loop. Repairs or routine system maintenance can be completed without introducing air into the system or draining the HTF.

The expansion tank shall have a minimum 150 PSIG working pressure and have a total volume of not less than 4.4 gallons. The standard factory charge should be 40 PSIG. The expansion tank shall be Rheem/Ruud Therm-X-Guard Model RRT-12 or equal (No. 8).

A high quality thermostatic mixing valve is a required component in all OG-300 certified systems and should be plumbed in line with brass union connections for ease of future repair or replacement (No. 32). The specified mixing valve shall be the Heatguard model HGBASE or equal and shall have an operating range between 95°F and 140°F. The mixing valve shall be set to 120°F.

P.10

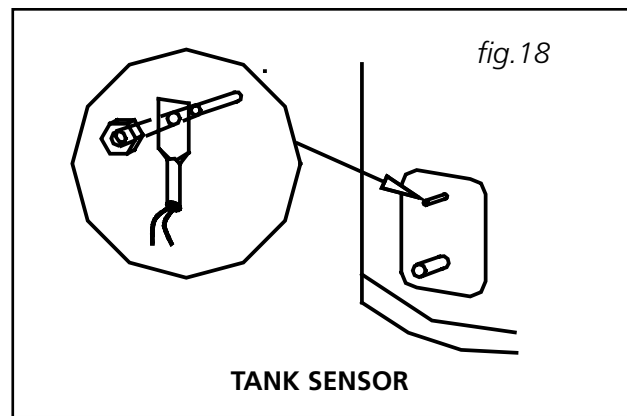

The temperatures generated by your SolaRay system will vary throughout the year. In the Northern Hemisphere the water temperature will be hottest in the spring and summer months while cooler temperatures are to be expected from November through March. On sunny days system temperatures may range between 110°F to 180°F depending upon the season and hot water demand. The mixing valve described above blends the hot and cold water supplies to deliver hot water to your fixtures at a safe, controlled temperature.

WARNING: SCALDING CAN OCCUR WITHIN FIVE SECONDS WHEN WATER TEMPERATURES APPROACH 140°F. THE MIXING VALVE SHOULD BE ADJUSTED BY YOUR CONTRACTOR TO PROVIDE WATER TO YOUR FIXTURES AT NO MORE THAN 120°F.

The 3/4" cold water supply line to the solar storage tank must be insulated with minimum 7/8" X 1/2" pipe insulation to a minimum distance of 5' behind the storage tank, or to the wall if closer than 5'.

4.9 Tank Sensor Placement

Figure 18 details the proper placement of the solar storage tank sensor. Make sure the sensor is secured to the threaded stud on the storage tank with a 10-24 stainless steel nut.

Thoroughly weatherize the wire connections in accordance with the roof sensor detail above. Replace the fiberglass insulation batting and close the access cover.

4.10 Tank Insulation

SunEarth requires that the solar storage tank must have a minimum insulation value of R-20.

Most solar storage tanks now come with R-16.7 factory insulation. Conventional back-up electric water heaters have insulation values between R-12 and R-20. The R value expresses the thermal conductivity of the insulation material. The higher the "R" value the more effective the insulation material is at preventing heat loss.

Whereas solar storage tanks do not come with sufficient factory insulation to meet SunEarth's insulation specification, a supplemental insulation jacket also must be installed. We recommend an aluminum foil "bubble-pack" insulation material such as manufactured by Reflectix (or equal). When properly applied, the insulation jacket will increase the overall level of the solar tank insulation to approximately R-22. In two tank retrofit installations an installation jacket also must be installed on the back-up water heater.

If your Solaray system is installed in a new home, SunEarth specifies that the conventional water heater in a two tank system have an insulation value of R-20 (Rheem 82VR52-2, Ruud EVR5202 or equal). Tanks with R-20 insulation or higher do not require a supplemental insulation jacket.

For best results, cut three 1" strips of material and affix these to the top, middle and bottom of your water heater or storage tank with the manufacturer's tape. This space creates an air gap between the heater and the insulation and prevents heat conduction. Wrap the material around the water heater or storage tank and secure the seams with the manufacturer's tape.

Thoroughly insulate the top of the water heater. Fit the insulation snugly around the brass nipples or unions and temperature and pressure relief valve on the top of the water heater. If you have an electric water heater, cut two windows in the insulation around the access plates covering the upper and lower thermostats and heating elements. Insulate the area over the access plates, but make sure that these areas always remain accessible for service or repair as necessary.

The storage tank should not be placed directly on an uninsulated floor or concrete slab. The tank should be placed on a well insulated pad with a minimum R-value of 10. A 2" rigid polystyrene insulation pad such as manufactured by Frost

King (or equal) is recommended.

4.11 Electrical and Wiring Requirements

A properly licensed contractor must make the 230 volt electrical connection to the water heater or solar storage tank and the electronic time switch (Optional No. 33). If your solar contractor is not allowed by law to make these connections consult a licensed electrician.

Never activate the circuit breaker controlling the electrical heating element until the solar storage tank is completely filled with water.

This will prevent "dry firing" of the heating element. The electrical heating element will be destroyed almost instantaneously if not completely submerged in water when activated. Make sure the water heater circuit breaker is off until the solar storage tank is completely filled.

We recommend the use of a 115 volt differential control with a factory installed six foot line cord. The installation requires one 115 volt outlet to be installed near the solar storage tank. Plug the control into the outlet. The circulation pump line cord is plugged into the receptacle on the side of the controller. A 230 volt control and circulation pump may be substituted, but troubleshooting the components in the future becomes more difficult.

The specified differential thermostat is the Independent Energy "Goldline" model GL-30-LCO (No. 18).

4.12 Charging the System

Once the components are plumbed you are ready to fill the solar storage tank with water and to charge the collector loop with a mixture of heat transfer fluid (HTF) and distilled or deionized water. The use of regular tap water as a mixing agent is prohibited.

Proceed as follows:

4.12.1 Begin by filling the solar tank with water. Do this by opening the cold water isolation ball valve to the solar tank (No. 23). When the tank is filled, inspect all threaded fittings and solder joints for leaks.

4.12.2 Fill and pressurize the solar collector loop with water. Begin by connecting a washing machine hose to the upper charge valve (No. 9)

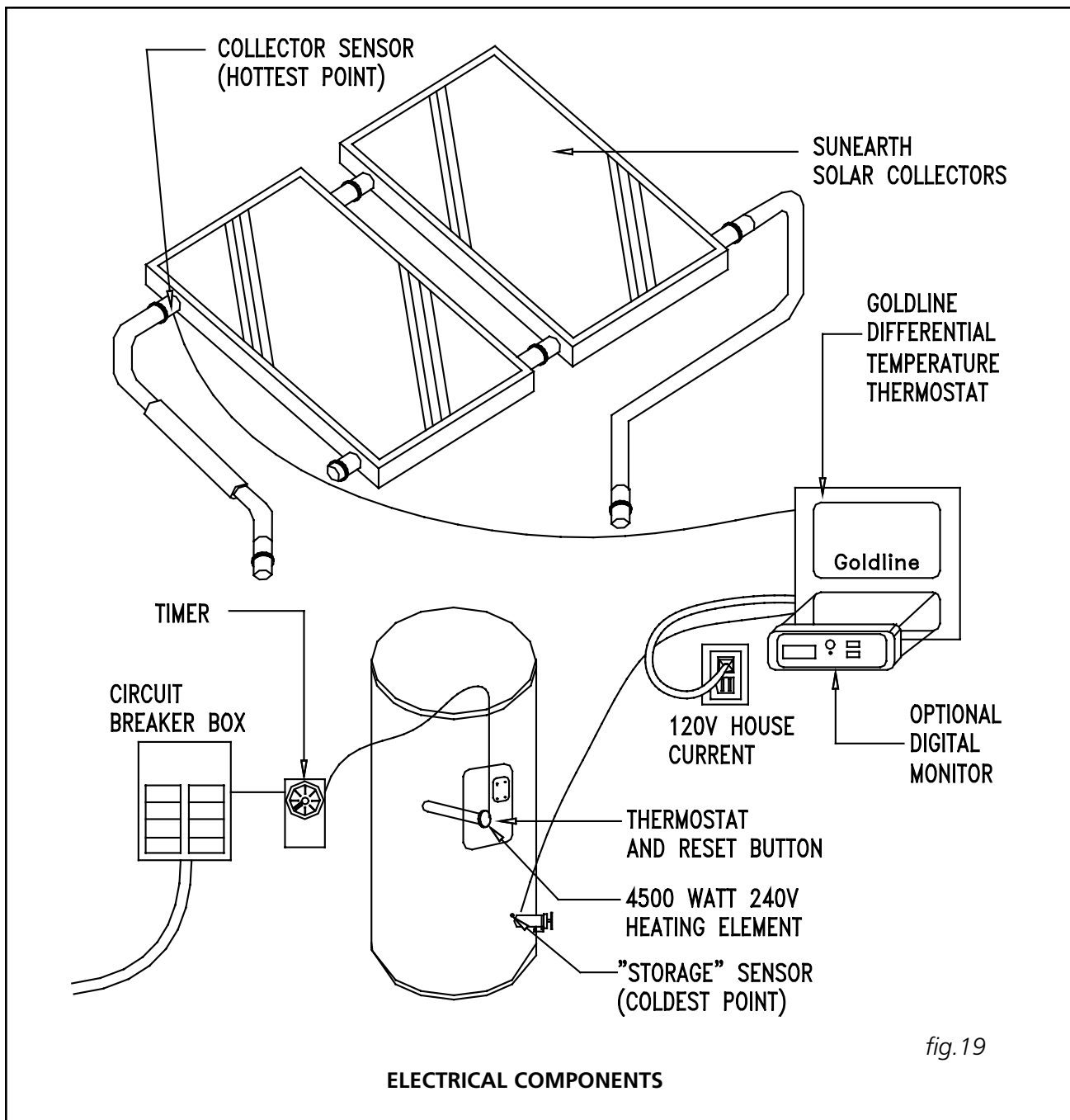

fig.19

and fill the collector loop with water. The isolation ball valve (No. 10) remains closed at this point. While the hose is still connected to the upper charge valve and the water is running, open the lower purge/drain valve (No. 11) and let the water run out until it is free of impurities or debris that might have entered the piping as the components were plumbed. Run the water long enough to eliminate any air bubbles that may be trapped in the system.

Close the lower purge/drain valve. The collector loop now has been subjected to city pressure and

the pressure gauge should read somewhere in the range of 50 - 75 PSI in most cases (No. 7). Make a final inspection of the collector plumbing connections to ensure that there are no leaks anywhere in the collector loop piping.

4.12.3 After you have determined the integrity of the entire piping system turn on the circulating pump. Do this by setting the manual switch within the controller to the "on" position. Run the pump for a full five minutes and carefully check to ensure there is proper fluid flow and that all the air has been purged from the solar

Table 4		
Percent (volume) Glycol Concentration Required		
Temperature F	For Freeze Protection	For Burst Protection
20	18%	12%
10	29	20
0	36	24
-10	42	28
-20	46	30
-30	50	33
-40	54	35
-50	57	35
-60	60	35

collector glycol loop. An inexpensive flow meter such as manufactured by Blue White Industries or Letro is recommended as an optional system component. A flow meter allows you to monitor and adjust the flow rate through the piping and also to visually inspect the HTF fluid quality.

Set the controller to the "off" position and proceed to the next step.

4.12.4 Mix the Dowfrost HD propylene glycol and distilled water mixture in accordance with Table 4 and Table 5 in a large clean bucket. You will need a second empty bucket as well. The charging process also will require a low flow diaphragm pump (Flojet or equal) to fill and pressurize the collector loop.

Connect the discharge side of the pressure pump to the upper charge faucet (No. 9) Place the pump suction side hose in the glycol solution. Close the isolation ball valve (No. 10) and connect a second hose to the lower charge faucet (No. 11). Place the other end of the hose in the empty bucket.

Table 5	
Total Collector Loop Fluid Capacity In Gallons*	
1 Collector System	4 Gallon
2 Collector System	5 Gallons

* Assumes a total 100' pipe run using 3/4" Type M hard copper tubing. The Rheem/Ruud heat exchanger has a 2.2 gallon fluid capacity.

Open the upper charge faucet and allow the pressure from the expansion tank to push the water in the glycol loop back to prime the pressure pump. When the hose in the bucket containing the glycol mixture stops bubbling you may begin charging the collector loop with glycol.

With both charge faucets now open, run the Flojet pressure pump until the pinkish glycol mixture begins flowing into the empty bucket. Quickly switch the hose from the empty/return bucket to the bucket containing the glycol mixture. Continue to circulate the fluid using the pressure pump until the bubbling has stopped and the air has been purged.

4.12.5 After charging the collector loop, shut the lower charge faucet and let the pressure pump drive up the loop pressure to the appropriate level (Generally in the range of 25 PSI). To more accurately calculate the proper pressure measure the height of the solar collector above the solar storage tank and divide this number by 2.31. Then add 20 PSI to this number. As a word of caution, the pressure in the glycol loop should not exceed 45 PSI when the system is operational on a good sunny day. Contact your solar contractor if the charged collector loop pressure exceeds this threshold.

Your SolaRay solar water heating system must be charged and the fluid quality maintained by an experienced contractor. If the system is drained during the winter, or you notice a significant drop in collector loop pressure, contact your installation contractor immediately for service. The glycol HTF provides the freeze protection for your system and must be properly maintained. An experienced contractor should periodically check the HTF fluid quality.

4.12.6 Dowfrost HD HTF

To ensure maximum effectiveness for corrosion protection, the glycol inhibitor package is designed for a minimum 25-30 percent concentration of glycol in water. Table 4 shows the concentrations of Dowfrost HD required to provide freeze and burst protection at various temperatures. Use the mixture most appropriate for your climate. Do not use a higher glycol to water concentration than necessary, as this will adversely impact the relative heat transfer efficiency of the solution.

Generally, for an extended margin of protection, you should select a temperature that is at least 5°F lower than the expected lowest ambient temperature. These figures are examples only and should not be regarded as specifications. As use conditions are not within our control, neither SunEarth nor Dow Chemical guarantees that freeze damage may not occur at temperatures other than shown.

Water used to dilute the HTF must meet certain minimum standards for purity. Impurities in the dilution water can increase metal corrosion, reduce the effectiveness of corrosion inhibitors, increase inhibitor depletion rate, and cause the formation of scale and other deposits on the heat exchanger's internal heat transfer surfaces.

Distilled or deionized water is required.

The HTF pH level must be maintained between 8 and 10 to minimize corrosion and glycol oxidation in the piping system.

5) SYSTEM START-UP PROCEDURES

Throughout the installation procedures outlined in Section 4 above, emphasis has been placed on the correct procedures for plumbing and wiring the components, checking for plumbing leaks, pressurizing the collector glycol loop, and eliminating any trapped air that can impact fluid quality and pump performance. Having completed these tasks it is time to start up your SolaRay solar water heating system.

When the glycol loop has been fully charged and the pressure is around 25 psi (check the pressure gauge, No. 7), set the differential controller to the "Automatic" setting. This will activate your circulating pump. The Goldline controller allows you to set the "on" differential. Turn the red rotary switch inside the control housing to 12.

The controller also allows you to limit the finished solar storage tank temperature if desired. Turn the red rotary switch inside the controller marked "Hi Limit" to the 160° setting. SunEarth does not recommend that the Hi Limit be set any lower than 160°.

Adjust the valve settings in accordance with Section 6 below.

6) THREE MODES OF SYSTEM OPERATION

Both single and double tank Solaray systems are

P.14

designed to accommodate three separate modes of operation. Your solar water heating system can, (1) provide 100% solar operation during good weather, or (2) serve as a preheater to your electric water heater adding solar energy when and as available, or (3) completely bypass the solar collector loop and solar storage tank and run 100% on utility power during inclement weather.

Single Tank Operating Instructions:

6.1 100% Solar Operation:

Turn off the circuit breaker to your solar storage tank. If a water heater time switch has been installed, set the switch to the "off" position. If you have a mechanical timer remove the trippers from the face of the switch.

6.2 Solar Preheat

Leave the circuit breaker to your solar storage tank on and set the tank thermostat to the lowest acceptable temperature setting. The electric resistance heating elements will come on only when the tank temperature falls below the thermostatic set point. If the solar heated water entering the tank is warmer than the thermostatic set point, the electric heating elements will not come on. If you have a water heater timer, you may preset the timer to turn the heating element on and off at specified times throughout the day if desired.

6.3 100% Utility Power

Leave the circuit breaker to your solar storage tank on and close the isolation ball valves in the collector loop (Nos. 5 and 10). In this mode of operation **you must turn off the circulation pump**. To turn the pump off open the controller and change the operational setting from automatic to off. Failure to turn off the pump can quickly damage the pump motor, shaft, bearings or impeller.

Two Tank System Instructions:

6.4 100% Solar Operation

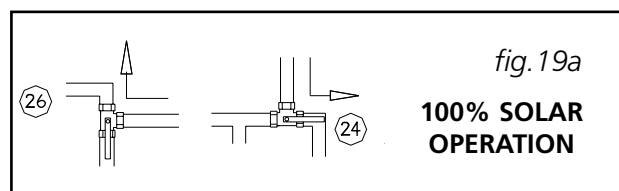

Follow the instructions for single tank systems above. You also must change the position of the three way ball valves above both the solar storage tank and the back-up water heater (Nos. 24 and 26). Valve handle No. 24 must be in the horizontal position. Valve handle No. 26 must be in the vertical position. See Figure 19a, 100% Solar Operation.

6.5 Solar Preheat

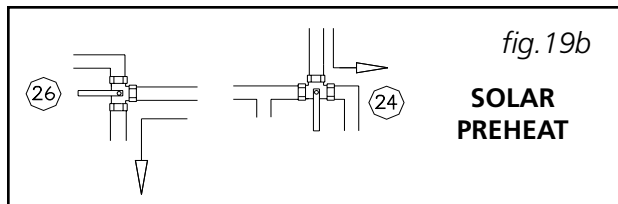

Follow the instructions for the single tank system for setting the thermostat and the heating elements for automatic operation. The three way valve above the solar storage tank (No. 24) must be in the vertical position. Each valve handle (Nos. 24, 25 and 26) must be placed in the horizontal position. See Figure 19b, Solar Preheat.

6.6 100% Utility Power

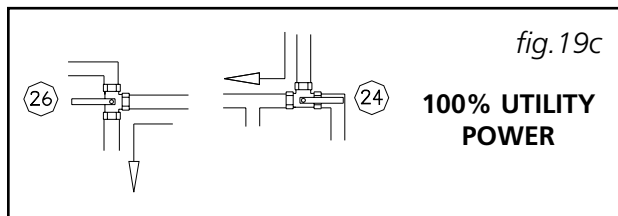

Follow the instructions for the single tank system above. All three ball valves above the heaters (Nos. 24, 25 and 26) must have the valve handles placed in the horizontal position. See Figures 19c 100% Utility Power and 19d.

7) ISOLATING THE MAJOR COMPONENTS AND SYSTEM

SHUT DOWN PROCEDURES

Your SolaRay solar water heating system is designed so that the key components can be easily isolated for emergency repairs or routine maintenance. By shutting a single valve you can isolate the entire system from the pressurized cold water supply line (No. 23). In the case of a storage tank or fitting leak immediately shut this valve and call your installation contractor for service.

The collector loop can be isolated from the solar storage tank by closing isolation ball valves Nos. 5 and 10. If the pressure in this loop drops or you find a glycol leak shut these valves and contact your installation contractor. Turn the circulating pump off by setting the controller to the "off" position.

In two tank systems the solar storage tank can be isolated from the back-up water heater.

Set the valve handle on the three way ball valve (No. 24) to the horizontal position and close the isolation ball valve (No. 25). By closing these two valves the tank can be serviced or replaced. The operation of the back-up water heater will not be effected.

The back-up water heater in two tank systems also can be isolated from the rest of the system. Close the cold water supply line ball valve (No. 23) and set the three way valve handle above the conventional water heater (No. 26) to the vertical position. Set the two way ball valve handle (No. 30) directly above the heater to the horizontal position.

8) SUMMER VACATION RECOMMENDATIONS AND PROCEDURES

Solar water heating systems can build up very high temperatures when there is no daily draw on the system. If a short summer vacation is planned the best way to dissi-

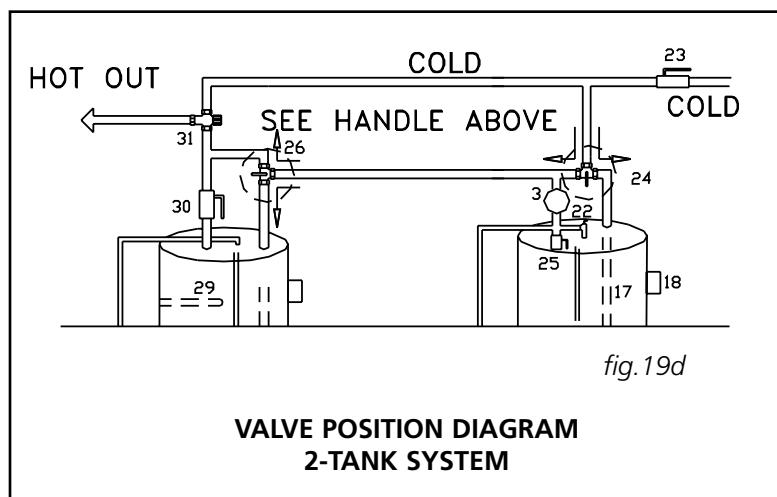

pate heat in the system is to set the controller to the "on" position. The circulating pump will run twenty-four hours a day and cool off the water in the solar storage tank at night. The collector radiates heat back to the atmosphere at night, preventing the system from stagnating at very high temperatures. This will not harm the pump or add substantially to your monthly utility bill. Remember to set the control to the "Automatic" setting upon your return!

During extended summer vacations (4 weeks or more) it is advisable to either cover the solar collectors with an opaque material or to manually drain the collector loop HTF. SunEarth recommends that you cover the collectors if practical.

If you choose to drain the HTF in the collector loop follow these steps:

8.1 Turn the controller to the "off" position (No. 18).

8.2 Connect one end of a garden hose to the purge/drain valve (No 11) and place the other end in a five gallon bucket. Open the valve and gravity will drain the heat transfer fluid into the bucket. A licensed recycler, reclaimer or incinerator must dispose of the Dowfrost HD. **DO NOT DUMP DOWFROST HD INTO A STORM SEWER, ON THE GROUND OR INTO ANY BODY OF WATER.**

BE CAREFUL. THE HTF MAY BE EXTREMELY HOT!

8.3 If the system is installed with an optional time clock make sure the clock is not preset to go "ON" during your absence. If you have a mechanical time switch, remove the "on" tripper from the clock face (No. 33).

When you return home contact your service contractor to recharge the system with HTF. After the system has been recharged, set the controller to the "automatic" position. Reset the time switch.

9) MAINTENANCE AND TROUBLESHOOTING

The following simple procedures are intended to optimize the performance of your SolaRay solar water heating system and also to extend the life of the primary components.

9.1 Fluid Quality: It is extremely important to

monitor the quality of the Dowfrost HD HTF on a periodic basis. The chemical composition of the heat transfer fluid may change over time. System pH must be maintained between 8 and 10 to avoid damage to the collector loop and absorber plate piping.

The specified glycol HTF is Dow Chemical "Dowfrost" HD. An extremely complete manual is available from the Dow Chemical Co. by calling 1-800-447-4369 Extension DOWFROST. Dow Chemical's "Engineering and Operating Guide for Dowfrost and Dowfrost HD" describes in detail the necessary procedures to maintain the integrity of the HTF. Ask your installation contractor to establish a maintenance schedule to inspect, balance or replace the glycol HTF as needed.

9.2 The second most important component in your system, at least from a longevity standpoint, is often ignored and never seen. We are referring to the sacrificial "anode rod" installed in your solar storage tank (No. 20). Typically constructed from magnesium, anode rods are installed in "glass lined" water heaters and storage tanks to inhibit corrosion.

As the name implies, the "sacrificial" anode rod is consumed so that the tank lining is not. At a certain point in the process, the anode rod is no longer completely effective and the corrosive processes begin to eat away at the tank's glass lining. In time the solar storage tank, like any other gas or electric water heater, will begin to leak. The process is not reversible and the tank must be replaced.

System temperatures and water quality affect the rate at which the anode rod is consumed. In general, the higher the average system temperature the faster the rate of corrosion. By changing the anode rod after the fifth year of system operation, and every three to five years thereafter, it is possible to extend the life of the solar storage tank. Periodic replacement of the anode rod in your solar storage tank can significantly extend the tank life.

9.3 The solar storage tank also should be flushed annually to minimize sediment build-up on the bottom of the tank. If you live in an area with high mineral content in your water, flush the tank on a semi-annual basis. Disconnect the power to

the solar tank at the circuit breaker or time switch (if present) before flushing. Turn the controller to the off position.

Open the flush valve on the bottom of the storage tank (No. 15) and drain a sufficient volume of water to eliminate the sediment. After the procedure is complete make sure the tank is completely full of water before restoring power to the thermostat and heating element. Turn the controller to the "on" position.

9.4 If you live in a dusty climate it is a good idea to wash off the dirt that settles on the collector glass once a month. Clean glass allows the collector to maintain a high level of thermal performance.

9.5 Check the exterior pipe insulation annually and patch or repair any exposed surfaces or degraded areas. Repaint as necessary.

9.6 In the unusual instance of collector glass breakage, the glass should be replaced immediately. This will reduce the likelihood of water accumulating inside the collector and deteriorating the insulation. Contact your installation contractor.

9.7 If you detect a glycol or water leak, or the glycol loop pressure drops unexpectedly, contact your installation contractor immediately to diagnose the problem and recharge the system.

9.8 If it's been a sunny day and you don't have hot water, first make sure that the controller is set in the automatic position. If the controller is properly set and the pump has not been running, unplug the line cord from the controller receptacle and plug the pump directly into a nearby 115 volt outlet. If the pump does not run it may need to be replaced. If the pump does run when plugged directly into the wall outlet, the problem may be located in the controller or one of the 10k ohm sensors. Contact your installation contractor for service.

9.9 If you have a full tank of hot water before bed and the solar storage tank is cold in the morning, the check valve (No. 4) may not be seating correctly and should be cleaned or replaced. Also make sure that the circulating pump is not running after 6:00 p.m. If the pump is running and the control indicator light "Solar" #1 is on after 6:00 p.m., check both sensors to see that they calibrate to 10K ohm resistance at 77°F. If you find a defec-

tive sensor replace it immediately.

Note that in a two tank system nighttime heat loss will be harder to detect, especially if you are operating in the solar preheat mode. Check the line thermometers (No. 3) in the collector loop piping to detect night thermosiphoning.

9.10 If the weather is poor and the auxiliary heating element will not fire, the bright red reset button on the thermostat may have to be depressed to be reset. Single tank systems have one heating element and thermostat. Double tank systems with conventional electric water heaters have two heating elements and thermostats (see fig 17, No. 29).

Never remove the protective access plate on the exterior of the solar storage tank or conventional water heater without disconnecting the 230 volt power supply at the circuit breaker.

After the circuit breaker has been turned off, remove the access plate on the storage tank or water heater and depress the red reset button on the thermostat. If it clicks when depressed the heating element should fire immediately when you reconnect the circuit breaker. If the reset button does not click and you do not have hot water after one hour, the heating element or thermostat may be defective. Contact your installation contractor for service.

In two tank systems the conventional electric water heater will be wired for electrical back-up. The solar tank will serve solely as a storage tank and will not be wired.

10) SOLARAY SYSTEM COMPONENT PARTS

See Figures 16 and 17 for the location of the specific components numbered below.

1) SunEarth Solar Collector(s): Absorbs the sun's heat energy and transfers this heat to the HTF circulating through the collector.

2) Collector Sensor: Wired to the system controller. Works in conjunction with the tank sensor to automatically turn your circulating pump on and off at preset temperature differentials.

3) Tank and Line Thermometers: Used to determine proper system operation. Line thermometers will show an approximate 5 - 12° temperature dif-

ference between the collector supply and return lines on sunny days. In a single tank system the tank thermometer will read the temperature of the water after the mixing valve feeding your fixtures. In two tank systems the thermometer will read the finished solar tank temperature.

4) Check Valve: This valve is installed to stop or minimize convective evening heat loss in the system. The heat in the solar storage tank will rise through the collector loop piping in the evening into the much cooler solar collector and dissipate heat unless prevented from doing so by a check valve. Check valves are also sometimes referred to as one way valves.

5) Isolation Ball Valve: Used in conjunction with component No. 10 to isolate the solar collector loop from the solar storage tank.

6) Pressure Relief Valve: Will release glycol loop HTF at 150 PSI. If this valve opens and HTF fluid is expelled contact your contractor immediately. This valve also can be opened to drain the HTF from the charged glycol loop for replacement.

7) Pressure Gauge: Indicates the pressure in the charged glycol collector loop.

8) Expansion Tank: Pre-charged with air to allow for the expansion and contraction of the glycol HTF as it heats and cools.

9) Charge Valve: Used to charge the collector loop with glycol and also to eliminate air from the system.

10) Isolation Ball Valve: Used in conjunction with component No. 5 to isolate the solar collector loop from the solar storage tank. Also used with the charge valves to fill and pressurize the collector glycol loop (Nos. 9 and 11).

11) Drain/Purge Valve: Used to charge the collector loop with glycol, purge air from the loop and drain the heat exchange fluid.

12) Isolation Ball Valve: When closed in conjunction with No. 14 will isolate the circulation pump for repair or replacement.

13) Circulating Pump: Circulates the HTF through the collector loop.

14) Isolation Ball Valve: When closed in conjunction with No. 12 will isolate the circulation pump for repair or replacement.

15) Flush Valve: Used to drain the solar storage tank and to flush sediment from the tank on an annual basis.

16) Tank Sensor: Wired to your controller. Works in conjunction with the collector sensor to turn your circulating pump on and off at preset temperature differentials.

17) Cold Water Dip Tube: Forces incoming city cold water to the bottom of the solar storage tank to prevent mixing with the warm water at the top of the tank.

18) Differential Thermostat: Known as the controller. Automatically turns the circulating pump on and off when there is sufficient heat to be gained from the solar operation. The controller also may be set to limit high temperature build up in the solar storage tank.

19) Heat Exchanger: Transfers heat from the solar collector loop to the potable water in the solar storage tank. The heat exchanger is double walled and vented. If a leak in the heat exchanger piping occurs there is no possibility that the potable water in your solar storage tank can be contaminated with the glycol HTF.

20) Anode Rod: The "sacrificial" anode rod is installed in your solar storage tank to prevent corrosion to the tank lining by neutralizing aggressive water action. Anode rods have a finite life and require periodic replacement depending on annual tank temperatures and water quality. Determine a replacement schedule with your installation contractor.

21) Heating Element & Tank Thermostat: The solar storage tank is equipped with an auxiliary 4500 watt, 230 volt electrical heating element. The thermostat controls the temperature setting of the auxiliary heating element.

22) Temperature and Pressure Relief Valve: Universally required by the plumbing code on water heaters. Will automatically release and dump water at either 150 PSI of pressure or 210° F in temperature.

23) Cold Water Supply Line Isolation Ball Valve: When open allows potable water to fill the solar storage tank or back-up water heater. When closed isolates the solar storage tank and back-up water heater from the pressurized city cold water supply line.

24) Three Way Ball Valve: Used in conjunction with component No. 26 to establish the proper mode of system operation.

25) Isolation Ball Valve: Used in conjunction with component No. 24 to completely isolate the solar storage tank for repair or replacement as necessary.

26) Three Way Ball Valve: Used in conjunction with component No. 24 to establish the proper mode of system operation.

27) Cold Water Dip Tube: See No.16 above.

28) Anode Rod: See No. 18 above.

29) Heating Elements and Thermostats: See No. 19 above. In a two tank system the back-up electric water heater has two heating elements and two thermostats.

30) Temperature and Pressure Relief Valve: See No. 22 above.

31) Optional Isolation Ball Valve. Use with component No. 26 to completely isolate the back-up water heater for repair or replacement.

32) Mixing Valve: Automatically blends hot water from the solar storage tank with incoming city cold water to an acceptable set point. A mixing valve must be installed on every SolaRay solar water heating system.

33) Optional Time Switch: Allows you to automatically or manually turn the auxiliary heating element in the solar storage tank on and off. A time switch is a highly recommended option.

11) ESTIMATED COMPONENT LIFE

You can expect a long useful life from the primary components in your SolaRay solar water heating system by adhering to the routine service and maintenance tips provided above.

The SunEarth solar collectors have a design life of twenty-five to thirty years. The HTF must be maintained as specified in this manual to maximize collector life. Photovoltaic modules have design lives in excess of twenty years. The solar storage tank should last 10 to 20 years in most water quality areas by periodically replacing the anode rod. The 12 volt DC circulating pump generally runs 20,000 hours before the brushes or motor require replacement. Like EPA mileage

estimates for automobiles, these component design lives represent average figures for closed loop forced circulation systems of this type installed in the United States.

To obtain warranty service contact your installation contractor or call SunEarth Inc. for the name of an authorized service agent near you.

12) SOLARAY SYSTEM MODEL NUMBERS

TYPE: 12 VOLT DC CIRCULATING PUMP AND PHOTOVOLTAIC MODULE

MODEL NUMBERS

SINGLE TANK SYSTEMS	DOUBLE TANK SYSTEMS
TE32P-80-1	TE32P-80-2
TE32C-80-1	TE32C-80-2
TE40P-80-1	TE40P-80-2
TE40C-80-1	TE40C-80-2
TE64P-80-1	TE64P-80-2
TE64C-80-1	TE64C-80-2
TE80P-80-1	TE80P-80-2
TE80C-80-1	TE80C-80-2

Example: TE64C-80-2

T = Tank Type, Double Wall Vented Heat Exchanger

E = Empire Series Collectors

64 = Nominal 64 Square Foot Collector Area

C = Chrome Absorber

80 = 80 Gallon Solar Tank

2 = 2 Tank System

G = Supplemental Gas Water Heater

Note: To substitute a semi-selective absorber plate coating, delete "C" and add "P".

To substitute the Imperial Series Collectors, the prefix becomes TI.

WWW.SUNEARTHINC.COM

PLEASE VISIT OUR WEB SITE FOR NEW PRODUCT UPDATES, ANSWERS TO FREQUENTLY ASKED QUESTIONS (FAQ) AND USEFUL INFORMATION ABOUT SOLAR WATER HEATING SYSTEMS.

THIS PAGE LEFT INTENTIONALLY BLANK

13) EMPIRE COLLECTOR SPECIFICATIONS

SunEarth Model No.	Width Inches	Length Inches	Depth Inches	Gross Area Sq Ft	Net Aperture Sq Ft	Dry Weight Lbs.	Fluid Capacity U.S. Gallons	Design Flow Rate GPM	Pressure Drop at Design Flow Rate	Max Flow Rate GPM	Maximum Operating Press PSIG	Std. Header Width, Inches	Std. Header Diameter, Inches Nominal	Header, Center to Center, Inches
EC/EP20	36 1/8	78 1/4	3 1/4	19.70	17.30	60	0.60	0.51	.015	12	160	39 3/4	1	73 1/2
EC/EP24	36 1/8	98 1/4	3 1/4	24.61	21.88	80	0.78	0.62	.017	12	160	39 3/4	1	93 5/8
EC/EP32	48 1/8	98 1/4	3 1/4	32.79	29.81	106	1.00	0.83	.018	12	160	51 3/8	1	93 5/8
EC/EP40	48 1/8	122 1/4	3 1/4	40.81	37.33	141	1.20	1.04	.020	12	160	51 3/8	1	115 5/8

MODEL EC

THERMAL PERFORMANCE RATINGS*

MODEL EP

Inch-Pound Units			
Btu/ft ² /Day			
Category (Ti-Ta)	CLEAR DAY 2000	MILDLY CLOUDY DAY 1500	CLOUDY DAY 1000
Ti = inlet fluid temp Ta = ambient air temp	Btu/ft ² /Day	Btu/ft ² /Day	Btu/ft ² /Day
A(-9°F)	1,332	1,005	680
B(9°F)	1,218	890	565
C(36°F)	1,040	720	402
D(90°F)	699	405	127
E(144°F)	390	137	-

Inch-Pound Units			
Btu/ft ² /Day			
Category (Ti-Ta)	CLEAR DAY 2000	MILDLY CLOUDY DAY 1500	CLOUDY DAY 1000
Ti = inlet fluid temp Ta = ambient air temp	Btu/ft ² /Day	Btu/ft ² /Day	Btu/ft ² /Day
A(-9°F)	1,284	971	659
B(9°F)	1,169	854	542
C(36°F)	984	677	372
D(90°F)	619	343	89
E(144°F)	280	62	-

A-Pool Heating (Warm Climate) B-Pool Heating C-Water Heating (Warm Climate) D-Water Heating (Cool Climate) E-Air Conditioning/Industrial Process Heat. Thermal performance is obtained by multiplying the collector output for the appropriate application and insolation level by the total gross collector area. *Collector ratings are derived from the Solar Rating & Certification Corp (SRCC) Document RM-1 and Standard OG-100.

The following shall be the specifications for the solar collectors. Collectors shall be SunEarth Empire model _____, and shall be of the glazed liquid flat plate type. Collectors shall be tested in conformance with ASHRAE 93-1986, and SRCC 100-81. The collectors also shall be certified by the SRCC and the Florida Solar Energy Center (FSEC).

GENERAL

The dimensions of the collector shall be _____ inches in length, _____ inches in width and 3 1/4 inches in depth. The collector casing shall be an anodized aluminum extrusion (alloy 6063 T5), minimum thickness .060 inch, with an architectural dark bronze finish. The casing shall have notched framewalls for ease of plate removal and reinstallation. Sheet metal screwed fasteners shall be stainless steel (18-8 #10). The backsheet shall be painted textured aluminum not less than .014 inch thickness. A 1 inch vent plug shall be installed in each of the four corners of the backsheet to minimize condensation.

GLAZING

The collector glazing shall be one sheet of low iron tempered glass, with a minimum of 1/8 inch thickness (5/32 inch on EP/EC 40), and a minimum transmissivity of 91 percent (89 on EP/EC 40). The glazing shall be thermally isolated from the casing by a continuous EPDM gasket. There shall be a continuous secondary silicone seal between the glass and casing capstrip to minimize moisture from entering the casing.

INSULATION

The insulation shall be foil-faced polyisocyanurate foam sheathing board of a minimum 1 inch thickness, siliconed in place to the aluminum backsheet, covered by low-binder fiberglass of a minimum 1 inch thickness, providing thermal isolation of the foam from the absorber plate. Total thermal resistance shall be a minimum of R-12. The sides and ends of the collector shall be insulated with a minimum of 1 inch foil-faced polyisocyanurate foam sheathing board.

ABSORBER PLATE AND PIPING

The absorber shall consist of a roll-formed copper plate of no less than .008 inch thickness. Risers shall be a minimum of 1/2 inch O.D. Type M copper tubing on no more than 4 1/2 inch centers continuously soldered to the plate utilizing a non-corrosive solder paste with a melting point of 460°F. The risers shall be brazed to 1 1/8 inch O. D. Type M copper manifolds utilizing a copper phosphorous brazing alloy with no less than 15 percent silver content, and conforming to the American Welding Society's BCuP-5 classification. EPDM grommets shall isolate the manifold from the aluminum casing. The absorber plate shall be designed for 160 psig maximum operating pressure.

ABSORBER COATING AND PERFORMANCE CURVE

A) Black Chrome (EC Series): The absorber coating shall be black chrome on nickel with a minimum absorptivity of 95 percent and a maximum emissivity of 12 percent. The instantaneous efficiency of the collector shall be a minimum Y-intercept of 0.714 and a slope of no less than -0.7271 (BTU/ft²-hr)/F.

B) Moderately Selective Black Paint (EP Series): The absorber coating shall be a moderately-selective black paint with a minimum absorptivity of 94 percent and a maximum emissivity of 56 percent. The instantaneous efficiency of the collector shall have a minimum Y-intercept of 0.682 and a slope of no less than -0.7995 (BTU/ft²-hr)/F.

Specifications subject to change without notice.

IMPERIAL COLLECTOR SPECIFICATIONS

SunEarth Model No.	Width Inches	Length Inches	Depth Inches	Gross Area Sq Ft	Net Aperture Sq Ft	Dry Weight, Lbs.	Fluid Capacity U.S. Gallons	Design Flow Rate GPM	Pressure Drop at Design Flow Rate	Max Flow Rate GPM	Maximum Operating Press PSIG	Std. Header Width, Inches	Std. Header Diameter, Inches Nominal	Header, Center to Center, Inches
IC/IP24	36 1/4	98 1/8	3 1/4	24.61	21.88	98	0.78	0.62	.017	12	160	39 3/4	1	93 5/8
IC/IP32	48 1/4	98 1/8	3 1/4	32.79	29.81	119	1.00	0.83	.018	12	160	51 3/8	1	93 5/8
IC/IP40	48 1/4	122 1/8	3 1/4	40.81	37.33	157	1.20	1.04	.020	12	160	51 3/8	1	115 5/8

MODEL IC

THERMAL PERFORMANCE RATINGS*

MODEL IP

Inch-Pound Units			
Btu/ft ² /Day			
Category (Ti-Ta)	CLEAR DAY 2000	MILDLY CLOUDY DAY 1500	CLOUDY DAY 1000
<small>Ti = inlet fluid temp Ta = ambient air temp</small>	Btu/ft ² /Day	Btu/ft ² /Day	Btu/ft ² /Day
A(-9°F)	1,332	1,005	680
B(9°F)	1,218	890	565
C(36°F)	1,040	720	402
D(90°F)	699	405	127
E(144°F)	390	137	-

Inch-Pound Units			
Btu/ft ² /Day			
Category (Ti-Ta)	CLEAR DAY 2000	MILDLY CLOUDY DAY 1500	CLOUDY DAY 1000
<small>Ti = inlet fluid temp Ta = ambient air temp</small>	Btu/ft ² /Day	Btu/ft ² /Day	Btu/ft ² /Day
A(-9°F)	1,284	971	659
B(9°F)	1,169	854	542
C(36°F)	984	677	372
D(90°F)	619	343	89
E(144°F)	280	62	-

A-Pool Heating (Warm Climate) B-Pool Heating C-Water Heating (Warm Climate) D-Water Heating (Cool Climate) E-Air Conditioning/Industrial Process Heat. Thermal performance is obtained by multiplying the collector output for the appropriate application and insolation level by the total gross collector area. *Collector ratings are derived from the Solar Rating & Certification Corp (SRCC) Document RM-1 and Standard OG-100.

The following shall be the specifications for the solar collectors. Collectors shall be SunEarth Imperial model _____, and shall be of the glazed liquid flat plate type. Collectors shall be tested in conformance with ASHRAE 93-1986, and SRCC 100-81. The collectors also shall be certified by the SRCC and the Florida Solar Energy Center (FSEC).

GENERAL

The dimensions of the collector shall be _____ inches in length, _____ inches in width and 3 1/4 inches in depth. The collector casing shall be an anodized aluminum extrusion (alloy 6063 T5), minimum thickness 1/8 inch, with an architectural dark bronze finish. The casing shall have notched framewalls for ease of plate removal and reinstallation. Machine nut and bolt fasteners shall be stainless steel (18-8 10/32). Mounting hardware shall attach to collector frame wall and require no penetration of the casing. The collector shall be wind load tested to 180 mph (84 psf). The backsheet shall be painted textured aluminum not less than .014 inch thickness. A 1 inch vent plug shall be installed in each of the four corners of the backsheet to minimize condensation.

GLAZING

The collector glazing shall be one sheet of low iron tempered glass, with a minimum of 1/8 inch thickness (5/32 inch on IP/IC 40), and a minimum transmissivity of 91 percent (89 on IP/IC 40). The glazing shall be thermally isolated from the casing by a continuous EPDM gasket. There shall be a continuous silicone seal between the glass and casing capstrip to minimize moisture from entering the casing.

INSULATION

The insulation shall be foil-faced polyisocyanurate foam sheathing board of a minimum 1 inch thickness, siliconed in place to the aluminum backsheet, covered by low-binder fiberglass of a minimum 1 inch thickness, providing thermal isolation of the foam from the absorber plate. Total thermal resistance shall be a minimum of R-12. The sides and ends of the collector shall be insulated with a minimum of 1/2 inch foil-faced polyisocyanurate foam sheathing board.

ABSORBER PLATE AND PIPING

The absorber shall consist of a roll-formed copper plate of no less than .008 inch thickness. Risers shall be a minimum of 1/2 inch O.D. Type M copper tubing on no more than 4 1/2 inch centers continuously soldered to the plate utilizing a non-corrosive solder paste with a melting point of 460°F. The risers shall be brazed to 1 1/8 inch O.D. Type M copper manifolds utilizing a copper phosphorous brazing alloy with no less than 15 percent silver content, and conforming to the American Welding Society's BCuP-5 classification. EPDM grommets shall isolate the manifold from the aluminum casing. The absorber plate shall be designed for 160 psig maximum operating pressure.

ABSORBER COATING AND PERFORMANCE CURVE

A) Black Chrome (IC Series): The absorber coating shall be black chrome on nickel with a minimum absorptivity of 95 percent and a maximum emissivity of 12 percent. The instantaneous efficiency of the collector shall be a minimum Y-intercept of 0.714 and a slope of no less than -0.7271 (BTU/ft²-hr)/F.

B) Moderately Selective Black Paint (IP Series): The absorber coating shall be a moderately-selective black paint with a minimum absorptivity of 94 percent and a maximum emissivity of 56 percent. The instantaneous efficiency of the collector shall have a minimum Y-intercept of 0.682 and a slope of no less than -0.7995 (BTU/ft²-hr)/F.

Specifications subject to change without notice.

(Performance specifications subject to testing error of +/- 3%)



SUNEARTH INC.
Quality Solar Energy Products

PRODUCT WARRANTY STATEMENT

**IMPERIAL, EMPIRE, SUNWISE AND SOLARSTAR COLLECTORS
SUNBURST ABSORBER PLATES AND COPPERHEART ICS**

TEN YEAR WARRANTY

Under conditions of normal use and service SunEarth Imperial, Empire, SunWise and SolarStar solar collectors, "SunBurst" absorber plates, and CopperHeart ICS units are warranted to the original or subsequent users for a period of ten (10) years from the date of sale. SunEarth's liability under this warranty shall be limited to repairing or replacing at SunEarth's option, without charge, F.O.B. SunEarth's factory or an authorized SunEarth distributor or service station, the Imperial, Empire, SunWise or SolarStar collector, "SunBurst" absorber plate, or CopperHeart ICS unit. SunEarth will not be liable for any costs of transportation, inspection, removal, reinstallation, or any other labor or freight charges that may arise in connection with a warranty claim except as expressly delineated in this warranty statement.

FIELD LABOR

Field labor to repair or replace any defective Imperial, Empire, SunWise, or SolarStar solar collector, "SunBurst" absorber plate, or CopperHeart ICS unit is reimbursable up to \$100 in year one, \$75 in years two through five, and \$50 in years six through ten.

FREIGHT AND SHIPPING EXPENSES

During the first year of warranty coverage SunEarth will pay the shipping costs for the new or repaired Imperial, Empire, SunWise or SolarStar solar collector, "SunBurst" absorber plate, or CopperHeart ICS between SunEarth and the nearest local distributor, dealer, or authorized service center. After the first year freight and packing costs are the responsibility of the owner and are not covered under this warranty.

THIS WARRANTY WILL NOT APPLY

This warranty does not apply to conditions resulting from a failed component or part that is not part of the Imperial, Empire, SunWise or SolarStar solar collector, "SunBurst" absorber plate, or CopperHeart ICS unit; to freeze damage; to conditions resulting from misuse, abuse, neglect, accident, or alteration; to minor discoloration of the collector framewall or absorber plate over time; to glass breakage; to conditions resulting from the introduction of harmful chemicals, caustic fluids, or liquids deleterious to copper tubing, including improperly applied or maintained heat transfer fluids; to propylene glycol pH levels above 10 or below 8; to periods of stagnation

in excess of 90 days; to excessive pressure; to erosion corrosion of the copper tubing resulting from excessive flow rates; to improper plumbing configurations that do not conform to SunEarth's manifolding requirements; to clouding or similar occurrence resulting from the normal intrusion of moisture into the box; to conditions resulting from floods, earthquakes, winds, fire, lightning, or circumstances beyond SunEarth's control; to installation methods that do not conform to relevant national, state or local codes and ordinances, good industry practices or applicable SunEarth manuals, diagrams, technical bulletins or written installation instructions; and to applications other than medium temperature (110 - 160F) domestic water heating. If the Imperial, Empire, SunWise or SolarStar solar collectors, "SunBurst" absorber plate or CopperHeart ICS are purchased outside the continental United States certain conditions of this warranty may not apply. Please contact your local SunEarth distributor.

HOW TO MAKE A CLAIM

To obtain service under this warranty, the defective product must be returned to the distributor or dealer of SunEarth products nearest you, an authorized SunEarth service center, or SunEarth directly. Each claim must be accompanied by documentation indicating the homeowner's name, address, phone number, date of installation, date of failure, reason for failure, product model and serial numbers, and the installation contractor's name and phone number. If you have questions regarding this warranty contact your installation contractor or SunEarth at 909-605-5610.

LIMITED WARRANTY

EXCEPT AS EXPRESSLY PROVIDED HEREIN, THE IMPERIAL, EMPIRE, SUNWISE OR SOLARSTAR COLLECTOR, "SUNBURST" ABSORBER PLATE, OR COPPERHEART ICS UNIT IS PROVIDED WITHOUT WARRANTY OF ANY KIND, EITHER EXPRESS OR IMPLIED, INCLUDING, BUT NOT LIMITED TO, THE IMPLIED WARRANTIES OF MERCHANTABILITY AND FITNESS FOR A PARTICULAR PURPOSE OR ANY WARRANTY OR NON-INFRINGEMENT. SOME STATES DO NOT ALLOW THE EXCLUSION OF IMPLIED WARRANTIES, SO THE ABOVE EXCLUSION MAY NOT APPLY TO YOU. THIS WARRANTY GIVES YOU SPECIFIC LEGAL RIGHTS, AND YOU MAY ALSO HAVE OTHER RIGHTS WHICH VARY FROM STATE TO STATE.

LIMITATIONS OF REMEDIES

IN NO EVENT WILL SUNEARTH BE LIABLE TO YOU FOR ANY DAMAGES, INCLUDING ANY LOST PROFITS, LOST SAVINGS OR OTHER INCIDENTAL OR CONSEQUENTIAL DAMAGES, ARISING OUT OF THE USE OR INABILITY TO USE THE IMPERIAL, EMPIRE, SUNWISE OR SOLARSTAR COLLECTOR, "SUNBURST" ABSORBER PLATE, OR COPPERHEART ICS, OR FOR ANY CLAIM BY ANY OTHER PARTY. SOME STATES DO NOT ALLOW THE LIMITATION OR EXCLUSION OF LIABILITY FOR INCIDENTAL OR CONSEQUENTIAL DAMAGES SO THE ABOVE LIMITATION MAY NOT APPLY TO YOU.

EXCLUSIVE AGREEMENT

THE WARRANTY CONTAINED HEREIN CONSTITUTES THE ENTIRE, COMPLETE, FINAL AND EXCLUSIVE AGREEMENT, AND SUPERSEDES ANY PROPOSAL OR AGREEMENT ORAL OR WRITTEN, AND ANY OTHER COMMUNICATIONS, BETWEEN SUNEARTH AND THE BUYER WITH RESPECT TO THE SUBJECT MATTER HEREOF.



4315 Santa Ana St. • Ontario, CA. 91761
Phone: (909) 605-5610 • Fax: (909) 605-5613
email: info@sunearthinc.com • www.sunearthinc.com